

# 11" Gear-Driven Sander

*Air Tool Manual – Safety, Operation and Maintenance*

SAVE THIS DOCUMENT, EDUCATE ALL PERSONNEL

## Models:

**58040 – 11" Pad, 3/16" Orbit, Non-Vac**

**58041 – 11" Pad, 3/16" Orbit, Central-Vac**



FIND THE MOST CURRENT OFFERING OF SUPPORT DOCUMENTS AND ACCESSORIES @ [WWW.DYNABRADE.COM](http://WWW.DYNABRADE.COM)

## ⚠ WARNING

Read and understand this tool manual before operating your air tool. Follow all safety rules for the protection of operating personnel as well as adjacent areas. Always operate, inspect and maintain this tool in accordance with the American National Safety Institute (ANSI) Safety Code for Portable Air Tools – B186.1. For additional safety information, refer to Safety Requirements for the Use, Care and Protection of Abrasive Wheels – ANSI B7.1, Code of Federal Regulation – CFR 29 Part 1910, European Committee for Standards (EN) Hand Held Non-Electric Power Tools – Safety Requirements and applicable State and Local Regulations.

## SAFETY LEGEND

	<b>⚠ WARNING</b> Read and understand tool manual before work starts to reduce risk of injury to operator, visitors, and tool.	<b>⚠ WARNING</b> Practice safety requirements. Work alert, have proper attire, and do not operate tools under the influence of alcohol or drugs.	
	<b>⚠ WARNING</b> Eye protection must be worn at all times, eye protection to conform to ANSI Z87.1.	<b>⚠ WARNING</b> Ear protection to be worn when exposure to sound, exceeds the limits of applicable Federal, State or local statutes, ordinances and/or regulations.	
	<b>⚠ WARNING</b> Respiratory protection to be used when exposed to contaminants that exceed the applicable threshold limit values required by law.	<b>⚠ WARNING</b> Air line hazard, pressurized supply lines and flexible hoses can cause serious injury. Do not use damaged, frayed or deteriorated air hoses and fittings.	

### ⚠ WARNING

Some dust created by sanding, grinding, drilling, and other construction activities contain chemicals known to cause cancer, birth defects or other reproductive harm. Some examples of these chemicals are:

- Lead from lead-based paints
- Crystalline silica from bricks and cement and other masonry products
- Arsenic and chromium from chemically treated lumber

Your risk from these exposures varies, depending on how often you do this type of work. To reduce your exposure to these chemicals: work in a well ventilated area, and work with approved safety equipment, such as those dust masks that are specially designed to filter out microscopic particles.

### SAFETY INSTRUCTIONS

Carefully Read all instructions before operating or servicing any Dynabrade® Abrasive Power Tool.

Products offered by Dynabrade are not to be modified, converted or otherwise altered from the original design without expressed written consent from Dynabrade, Inc.

**Tool Intent:** 11" Gear-Driven Sander are ideal for removal and polishing of materials using deburring, cleaning and polishing accessories.

**Do Not Use Tool For Anything Other Than Intended Applications.**

This power tool is not intended for use in potentially explosive atmospheres and is not insulated against contact with electrical power.

**Training:** Proper care, maintenance, and storage of your tool will maximize their performance.

- Employer's Responsibility – Provide 11" Gear-Driven Sander operators with safety instructions and training for safe use of tools and accessories.

#### Accessory Selection:

- Abrasive/accessory RPM (speed) rating MUST be approved for AT LEAST the tool RPM rating.
- Before mounting an accessory, visually inspect for defects. Do not use defective accessories.
- Use only recommended accessories. See back page of manual and Dynabrade catalog.
- Follow tool specifications before choosing size and type of accessory.
- Only use recommended fittings and air line sizes. Air supply hoses and air hose assemblies must have a minimum working pressure rating of 150 PSIG (10 Bars, g) or 150 percent of the maximum pressure produced in the system, whichever is higher. (See tool Machine Specifications table.)

## OPERATING INSTRUCTIONS

**Warning:** Always wear eye protection. Operator of tool is responsible for following: accepted eye, face, respiratory, hearing and body protection.

**Caution:** Hand, wrist and arm injury may result from repetitive work, motion and overexposure to vibration.

- Keep hand and clothing away from working end of the air tool.

**Operation:** Be sure that any loose clothing, hair and all jewelry is properly restrained.

- Secure inlet bushing on air tool with a wrench before attempting to install the air fitting to avoid damaging housing assembly.
- BEFORE MOUNTING AN ACCESSORY, after all tool repairs and whenever a 11" Gear-Driven Sander is issued for use, check tool RPM (speed) with tachometer with air pressure set at 90 PSIG while the tool is running. If tool is operating at a higher speed than the RPM marked on the tool housing, or operating improperly, the tool must be serviced and corrected before use.

**Caution:** Tool RPM must never exceed abrasive/accessory RPM rating. Check accessory manufacturer for details on maximum operating speed or special mounting instructions.

- With power source connected at the air tool relieve hose of air pressure and disconnect tool from air supply when changing recommended accessories.
- Connect air tool to power source. Be careful NOT to depress throttle lever in the process.
- Do not expose air tool to inlet pressure above 90 PSIG or (6.2 Bars).

**Caution:** After installing the accessory, before testing or use and/or after reassembling tool, the 11" Gear-Driven Sander must be started at a reduced speed to check for good balance. Gradually increase tool speed. DO NOT USE if tool vibration is excessive. Correct cause, and retest to insure safe operation.

- Use only coated abrasive sanding discs or sheets properly secured to the backing pad provided with the air sander. Ensure that self-fixing sanding discs are mounted concentrically.
- Make sure that work area is uncluttered, and visitors are at a safe range from the tools and debris. Potentially explosive atmospheres can be caused by dust and fumes resulting from sanding or grinding. Always use dust extraction or suppression systems which are suitable for the material being processed.
- Proceed with caution in unfamiliar surroundings. Hidden hazards may exist, such as electricity or other utility lines.
- Air tools are not intended for use in explosive atmospheres and are not insulated for contact with electric power sources.
- Use a vise or clamping device to hold work piece firmly in place.
- Work may generate hazardous dust.
- Do not apply excessive force on tool or apply "rough" treatment to it.
- Always work with a firm footing, posture and proper lighting.
- Ensure that sparks and debris resulting from work do not create a hazard.
- This tool is rear exhaust. Exhaust may contain lubricants, vane material, bearing grease, and other materials flushed thru the tool.

**Report to your supervisor any condition of the tool, accessories, or operation you consider unsafe.**

## Air System

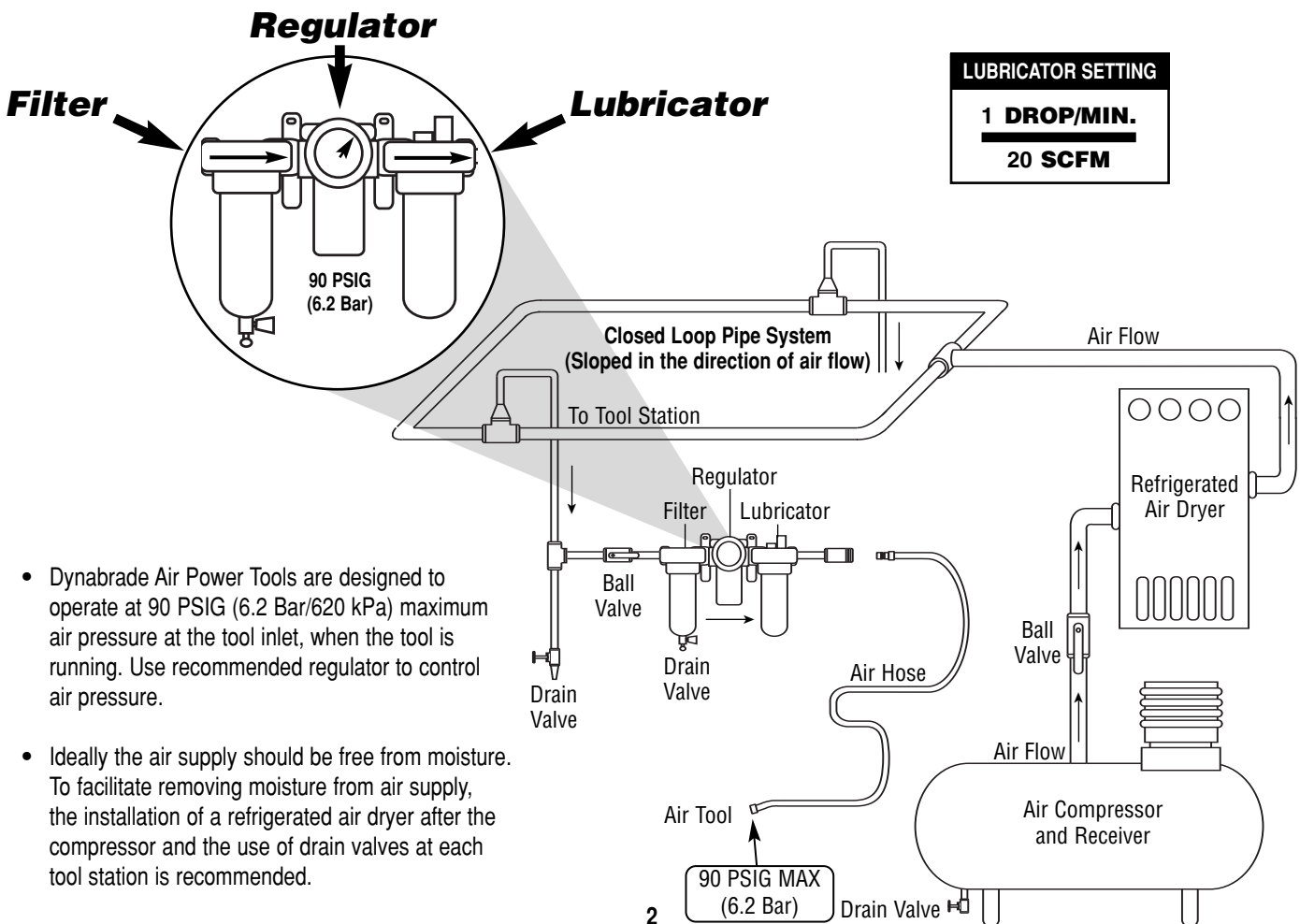

- Dynabrade Air Power Tools are designed to operate at 90 PSIG (6.2 Bar/620 kPa) maximum air pressure at the tool inlet, when the tool is running. Use recommended regulator to control air pressure.
- Ideally the air supply should be free from moisture. To facilitate removing moisture from air supply, the installation of a refrigerated air dryer after the compressor and the use of drain valves at each tool station is recommended.

# Maintenance Instructions

**Important:** A preventative maintenance program is recommended whenever portable power tools are used. The program should include inspection of air supply lines, air line pressure, proper lubrication and repair of tools. Refer to ANSI B186.1 for additional maintenance information.

- Use only genuine Dynabrade replacement parts to insure quality. To order replacement parts, specify **Model#**, **Serial#** and **RPM** of your air tool.
- It is strongly recommended that all Dynabrade rotary vane air tools be used with a Filter-Regulator-Lubricator to minimize the possibility of misuse due to unclean air, wet air or insufficient lubrication. Dynabrade recommends the following: **11405** Air Filter-Regulator-Lubricator (FRL) – Provides accurate air pressure regulation and two stage filtration of water contaminants. Operates 40 SCFM @ 100 PSIG with 3/8" NPT female ports.
- **Use the 95541 Grease Gun to apply 2 full plunges of the 95542 Grease through the grease fitting located in the 56452 Mount Plate Assembly. Two full plunges of grease should be applied after every 300-hour interval of use.**
- Dynabrade recommends one drop of air lube per minute for each 20 SCFM (example: if the tool specification states 40 SCFM, set the drip rate on the filter-lubricator to 2 drops per minute). Dynabrade Air Lube (P/N **95842**: 1 pt 473 ml) is recommended.

## Routine Preventative Maintenance:

- Check free speed of 11" Gear-Driven Sander by using a tachometer on regular basis.
- Mineral spirits are recommended when cleaning the tool and parts. Do not clean tool or parts with any solvents or oils containing acids, esters, ketones, chlorinated hydrocarbons or nitro carbons.
- **DO NOT** clean or maintain tools with chemicals that have a low flash point (example: WD-40®).
- A Motor Tune-Up Kit (P/N **96576**) is available which includes high wear and medium wear motor parts.
- Air tool labels must be kept legible at all times, if not, reorder label(s) and replace. User is responsible for maintaining specification information i.e.: Model #, S/N, and RPM. (See Assembly Breakdown)
- Blow air supply hose out prior to initial use.
- Visually inspect air hoses and fittings for frays, visible damage and signs of deterioration. Replace damaged or worn components.
- Refer to Dynabrade's Warning/Safety Operating Instructions Tag (Reorder No. **95903**) for safety information.

After maintenance is performed on tool, add a few drops of Dynabrade Air Lube (P/N **95842**) to the air line and start the tool a few times to lubricate air motor. Check for excessive tool vibration.

## Handling and Storage:

- Use of tool rests, hangers and/or balancers is recommended.
- Protect tool inlet from debris (see Notice below).
- **DO NOT** carry tool by air hose, or near the tool throttle lever.
- Protect abrasive accessories from exposure to water, solvents, high humidity, freezing temperature and extreme temperature changes.
- Store accessories in protective racks or compartments to prevent damage.
- Air tools are not intended for use in explosive atmospheres and are not insulated for contact with electrical power sources. Sanding/Grinding certain materials can create explosive dust. It is the employers responsibility to notify the user of acceptable dust levels. Sanding/Grinding can cause sparks which can cause fires or explosions. It is the users responsibility to make sure the work area is free of flammable materials.

## Machine Specifications

Model Number	Motor hp (W)	Motor RPM	Pad Dia. Inch (mm)	Sound Level	Maximum Air Flow CFM/SCFM (LPM)	Hose I.D. Size	Air Inlet Thread	Weight Pound (kg)	Length Inch (mm)	Height Inch (mm)
58040	.45 (336)	950	11 (279)	86 dB(A)	3/23 (651)	1/4" or 8mm	1/4" NPT	5.0 (2.3)	14-3/32 (358)	5-10/16 (143)
58041	.45 (336)	950	11 (279)	86 dB(A)	3/23 (651)	1/4" or 8mm	1/4" NPT	5.5 (2.5)	14-3/32 (358)	5-10/16 (143)

Additional Specifications: Air Pressure 90 PSIG (6.2 Bar)

## Notice

All Dynabrade motors use the highest quality parts and materials available and are machined to exacting tolerances. The failure of quality pneumatic motors can most often be traced to an unclean air supply or the lack of lubrication. Air pressure easily forces dirt or water contained in the air supply into motor bearings causing early failure. It often scores the cylinder walls and the rotor blades resulting in limited efficiency and power. Our warranty obligation is contingent upon proper use of our tools and cannot apply to equipment which has been subjected to misuse such as unclean air, wet air or a lack of lubrication during the use of this tool.

## One Year Warranty

Following the reasonable assumption that any inherent defect which might prevail in a product will become apparent to the user within one year from the date of purchase, all equipment of our manufacture is warranted against defects in workmanship and materials under normal use and service. We shall repair or replace at our factory, any equipment or part thereof which shall, within one year after delivery to the original purchaser, indicate upon our examination to have been defective. Our obligation is contingent upon proper use of Dynabrade tools in accordance with factory recommendations, instructions and safety practices. It shall not apply to equipment which has been subject to misuse, negligence, accident or tampering in any way so as to affect its normal performance. Normally wearable parts such as bearings, contact wheels, rotor blades, etc., are not covered under this warranty.

# 11" Gear-Driven Sander Complete Assembly

## Index Key

No.	Part #	Description
1	97010	Screw (5)
2	95886	Washer (5)
3	56231	11" Pad (Optional Pads Pg.8)
4	96477	Screw
5	<b>Balance Arm Assembly:</b> 59277	11"
6	56474	Balancer Washer
7	56452	Mount Plate Assembly
8	<b>Shroud:</b> 56489	Non-Vacuum
	61368	Vacuum Shroud Assy. Assembly Includes:
A	61361	Lip Seal
B	95886	Washer (6)
C	96425	Screw (6)
D	61362	1-1/4" Vac Adapter
9	01673	Pin
10	56589	Shaft
11	54673	Key
12	56133	Bearing
13	57749	Pinion Gear
14	57332	Lock Ring
15	96166	Set Screw
16	56559	Front Bearing Plate
17	54705	Rotor/Blade Set (5/pkg.)
18	56495	Cylinder (Includes: 95865 & 96313 Pins)
19	95911	O-Ring
20	54629	Rear Bearing Plate
21	01206	Bearing
22	95626	Retaining Ring
23	<b>Housing:</b> See Chart (Includes: 56581 Grip)	
24	95627	Pin
25	56582	Safety Throttle Lever
26	98459	O-Ring
27	56579	Valve Stem
28	56578	Speed Regulator
29	01025	O-Ring (3)
30	56598	Seal
31	51944	Tip Valve
32	51943	Spring
33	56586*	Vacuum Plug
34	56469	Exhaust Gasket
35	96459	O-Ring
36	56468	Handle Assembly (Includes: 51938 Screen)
37	96469	Screw (2)
38	96454	Screw (2)
39	56597*	Muffler
40	56596*	Muffler Clip

## Label Key

No.	Part #	Description
41	00000905	Warning Label

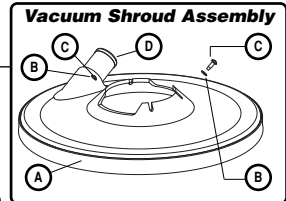
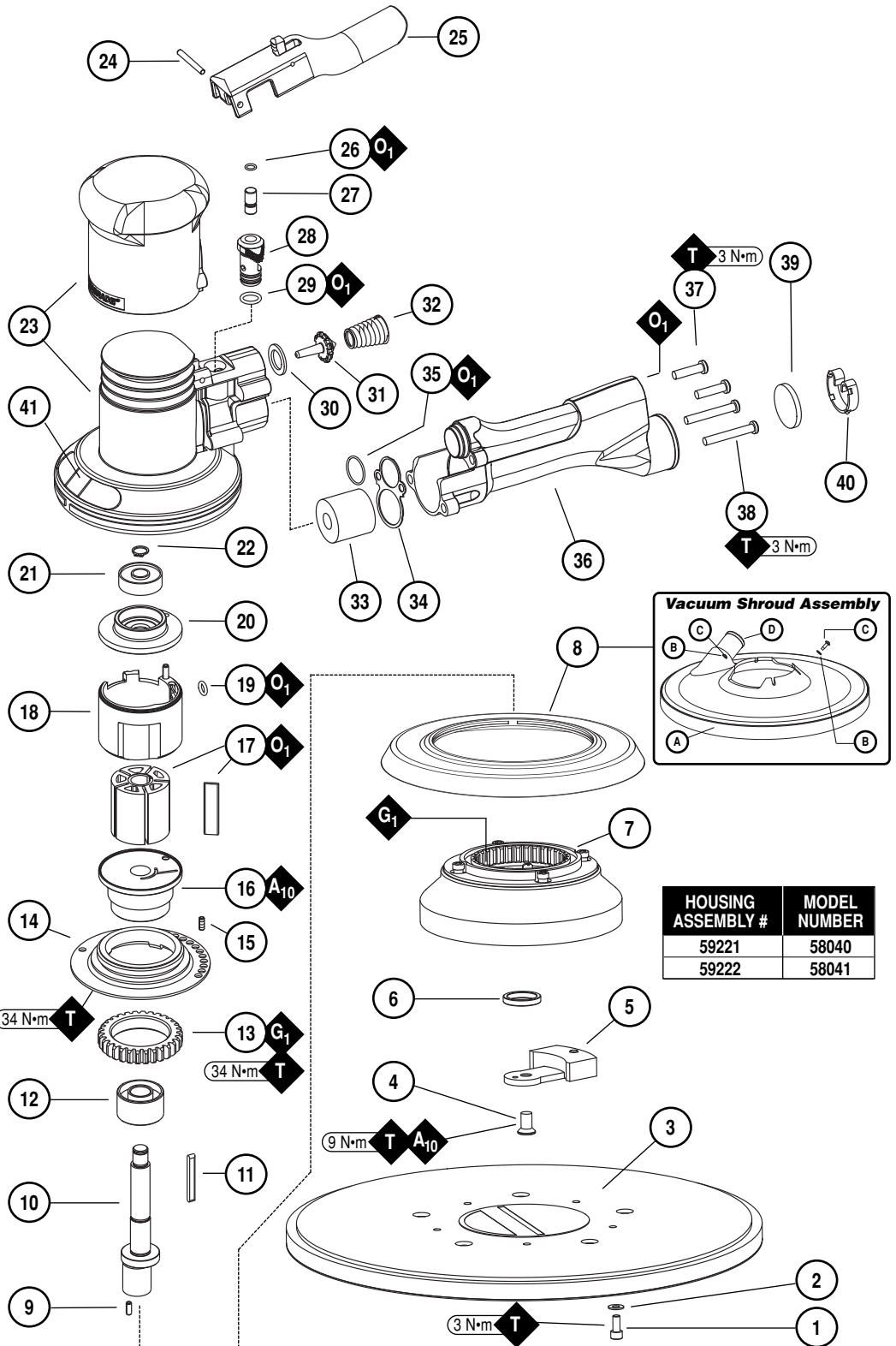

HOUSING ASSEMBLY #	MODEL NUMBER
59221	58040
59222	58041

KEY	
<b>O</b>	Oil: O <sub>1</sub> = Air Lube
<b>A</b>	Adhesive: A <sub>10</sub> = Loctite #243
<b>T</b>	Torque: N·m x 8.85 = In. - lbs.
<b>G</b>	Grease: G <sub>1</sub> = Lubriplate 630 AA

\*Parts included with Non-Vacuum Models Only.

## Disassembly/Assembly Instructions

**Important: The manufacturer's warranty is void if the tool is disassembled before the warranty expires. Use these instructions in conjunction with the Part Number 96283 Tool Repair Kit. This kit includes special tooling for the proper disassembly/assembly of the Two-Hand Gear-Driven Sander. This Tooling will be referred to in these instructions. An air motor Tune-Up Kit, Part Number 98221 is also available. It contains the high and medium wear components that most commonly need replacement.**

### Motor Disassembly:

1. Shut the air supply and disconnect the sander from the air supply hose.
2. Use the **57092** Repair Collar to hold the sander in a vise. Position the sander so that the backing pad is facing up. **Note:** Do not over tighten the collar and sander in the vise. Hold the sander snugly, so that the motor lock ring can be removed easily.
3. Use a 9/64" hex key wrench to remove the screws and backing pad from the sander.
4. Use a 4mm hex key wrench to remove the balance arm assembly by turning the hex key counterclockwise.
5. Remove the **56474** Balance Washer and **56452** Mount Plate Assembly. Remove **96166** Set Screw.
6. Use the **56599** Lock Ring Tool to remove the **57332** Lock Ring by turning it counterclockwise.
7. Pull the air motor assembly out of the housing.
8. Use retaining ring pliers to remove the **95626** Retaining Ring.
9. Remove the **95911** O-Ring from the **56495** Cylinder and fasten a 2" bearing separator around the part of the cylinder that is closest to the **54629** Rear Bearing Plate.
10. Place the air motor with the bearing separator attached, onto the table of the **96232**, #2 Arbor Press so that the balance end of the **56589** Shaft is pointing down.
11. Use a 5/16" dia. flat end drive punch as a press tool to push the shaft out of the **01206** Bearing. Use the **96213** Bearing Removal Tool to push the **01206** Bearing out of the **54629** Rear Bearing Plate. Note: This bearing removal tool is not included in the **96283** Repair Kit. Use the removal tool to push the **01206** Bearing out of the **54629** Rear Bearing Plate.
12. Remove the cylinder, rotor, vanes, and key.
13. Secure the **96249** Collar around the outside diameter of the **56559** Front Bearing Plate.
14. Secure the collar in a vise so that the pinion gear is facing up. Use a Heat Gun to apply heat to the pinion gear. Use the **96181** Pinion Wrench or adjustable groove pliers to grip the pinion gear and turn counterclockwise to remove it from the **56559** Front Bearing Plate.
15. Use a 2" bearing separator and arbor press to remove the **57749** Pinion Gear from the **56559** Front Bearing Plate.
16. Disassemble mounting plate sub-assembly:
  - a.) Remove **96276** Nuts (4) and **96274** Screws then lift out gear.
  - b.) Remove **96118** Screws (3).
  - c.) Press out **96423** Bearing by using **57091** Bearing Press Tool.

**Motor Disassembly Complete.**

### Motor Assembly:

**Important: Clean and inspect all motor parts for wear or defect.**

1. Install **56133** Bearing on the balance end of the **56589** Shaft.
2. Use the small end of the **50791** Bearing Press Tool and the **96232**, #2 Arbor Press to push the **56133** Bearing onto the shaft until the I.D. of the bearing sits against the shaft step. (Drawing 1)
3. Install the **57332** Lock Ring onto the **56559** Front Bearing Plate so that the threaded portion of the lock ring sits against the bearing plate.
4. Secure the **96249** Collar around the outside diameter of the **56559** Front Bearing Plate.
5. Secure the collar in a vise so that the thread of the lock ring is facing up. Apply a small amount of Loctite #243 (or equivalent) to the thread of the lock ring. Position the counter-bored end of the pinion gear toward the lock ring. By hand install the pinion gear. Use the **96181** Pinion Wrench or adjustable groove pliers to grip the pinion gear and turn clockwise to secure it to the **56559** Front Bearing Plate. (Torque to 34•Nm/300 in. lbs.)
6. Mounting Plate Sub-Assembly:
  - a.) Press **96423** Bearing into mounting plate.
  - b.) Insert **96118** Screws (3) and apply 1 drop of #271 Loctite® (or equivalent). **Note:** All screws should be hand tight before torque is applied.
  - c.) Press **57749** Gear into mounting plate, making sure to align mounting holes and that the **96273** O-Ring on back of gear is in place before assembly to mounting plate.
  - d.) Insert **96275** Washers into c-bore in gear.
  - e.) Apply 1 drop of #271 Loctite® (or equivalent) to **96274** Screws (4), insert through gear and thread into mounting plate torque 7 N•m/60 in. - lbs. Insert **96276** Nuts (4) and torque 7 N•m/60 in. - lbs.
7. Use the large end of the **57091** Bearing press Tool and the arbor press to install the front bearing plate onto the **56133** Bearing. (Drawing 2)
8. Install the **54673** Key so that the 90° side of the key fits into the keyway of the shaft and the tapered side of the key fits into the rotor. Install the **54705** Rotor/Blade Set (5) onto the shaft
9. Apply the **95842** Dynabrade Air Lube (10W/NR or equivalent) to the blades.
10. Install the **56495** Cylinder over the rotor so that the short line-up pin fits into the front bearing plate.
11. Place the **54629** Rear Bearing Plate over the shaft so that the long line-up pin fits through the hole in the rear bearing plate. (Drawing 3) Use the small end of the **57091** Bearing Press Tool to install the **01206** Bearing onto the shaft and into the **54629** Rear Bearing Plate. Use the press tool and the arbor press to install these so that there is a snug fit between the bearing plates and the cylinder. **Note:** Carefully press the **01206** Bearing onto the motor shaft until it touches against the bearing seat on the inside of the bearing plate. (Drawing 4)
12. Use retaining ring pliers to install the **95626** Retaining Ring so that the concave side of the ring is toward the motor assembly. **Note:** Be sure that the retaining ring is completely pressed down into the groove on the shaft.
13. Use the **57092** Repair Collar to hold the housing in a vise so that the opening for the housing is facing up. **Note:** Do not over tighten the collar and housing in the vise. Only hold the housing snugly, so that the motor and lock ring can be installed easily.
14. Apply a small amount of petroleum lubricant to the **95911** O-Ring and install the o-ring into the air inlet hole in the cylinder.
15. Install the motor assembly into the housing making sure to align the line-up pin with the line-up hole that is on the inside of the housing.
16. Use the **56599** Lock Ring Tool to secure the motor in the housing. (Torque to 34 N•m/300 in. lbs.) Align holes in **57332** Lock Ring with holes in housing.
17. Use 2mm hex key and install **96166** Set Screw into the housing through one of the holes in the lock ring until set screw is flush with the top of the lock ring.
18. Install the appropriate shroud onto the housing.
19. Apply a small amount of the **95542** Grease to the mount plate gear and then install the **56452** Mount Plate Assembly and the **56474** Balance Washer onto the **56589** Shaft. Apply a small amount of the Loctite #243 (or equivalent) to the threads of the **96477** Screw. Hold the balance arm assembly stationary with an adjustable wrench and use a 5/32" hex key to tighten the **96477** Screw by turning it clockwise. (Torque to 9N•m/80 in. lbs.)
20. Use the **95541** Grease Gun to apply 2 full plunges of the **95542** Grease through the grease fitting that is located in the **56452** Mount Plate Assembly. Two full plunges of grease should be applied after every 300-hour interval of use.
21. Use a 9/64" hex key wrench to install a weight-mated sanding pad.

**Motor Assembly Complete.**

## Disassembly/Assembly Instructions

### Handle and Valve Disassembly:

1. Place the **57092** Repair Collar around the housing so that the handle is pointing up.
2. Use a Phillips® screwdriver to remove the four screws that fasten the handle to the housing. Carefully pull the handle from the housing. This provides access to the tip valve components, also the handle o-ring, gasket and vacuum plug.
3. Use a 1/8" dia. flat end drive punch to remove the **95627** Pin and the **56582** Safety Throttle Lever.
4. Pull the **56578** Speed Regulator and valve stem out of the housing.

### Handle and Valve Disassembly Complete.

### Handle and Valve Assembly:

1. Place the **57092** Repair Collar around the housing so that the handle mounting area is facing up.
2. Install the **01025** O-Rings (3) onto the **56578** Speed Regulator, apply a small amount of petroleum lubricant to the o-rings and insert the regulator assembly into the housing. **Note:** Be careful that the o-rings do not get caught and pulled out of the o-ring grooves.
3. Install the **98459** O-Ring onto the **56579** Valve Stem, apply a small amount of petroleum lubricant to the o-ring and insert the shortest portion (from the end to the o-ring) of the valve stem assembly into the speed regulator.
4. Install the **56582** Safety Throttle Lever onto the housing and secure it in place with the **95627** Pin.
5. Install the **56598** Seal into the air inlet passage of the housing.
6. Install the **56586** Vacuum Plug into the exhaust passage of the housing. (See Exploded View)
7. Use needle-nose pliers to grasp and install the **51944** Tip Valve so that it fits under the end of the **56579** Valve Stem.
8. Install the large end of the **51943** Spring into the air inlet passage of the handle.
9. Install the **56469** Gasket onto the mounting surface of the handle.
10. Apply a small amount of petroleum lubricant to the **96459** O-Ring and install it onto outside diameter of the air inlet passage at the location of the first shoulder.
11. Connect the handle to the housing and secure it in place with the four screws. **Note:** The two longer screws, Part Number **96454** (2) secure the **56581** Grip to the housing.
12. Install the **56597** Muffler and secure it in place with the **56596** Muffler Clip. (See Exploded View)

### Handle and Valve Assembly Complete. Tool Assembly Complete. Please allow 30 minutes for adhesives to cure before operating tool.

**Important:** Motor should now be tested for proper operation at 90 PSIG. If motor does not operate properly or operates at a higher RPM than marked on the tool, the tool should be serviced to correct the cause before use. Before operating, place 2-3 drops of Dynabrade Air Lube (P/N **95842**) directly into air inlet with throttle lever depressed. Operate tool for 30 seconds to determine if tool is operating properly and to allow lubricating oils to properly penetrate motor.

Loctite® is a registered trademark of Loctite Corp.

## Diagrams

**Drawing 1**

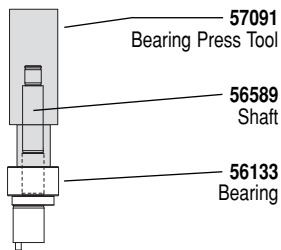

**Drawing 2**

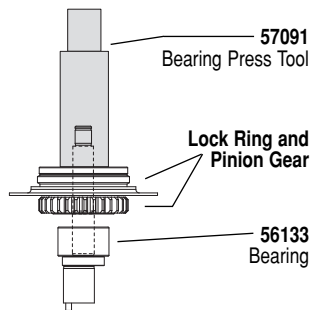

**Drawing 3**

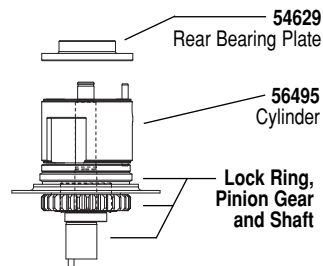

**Drawing 4**

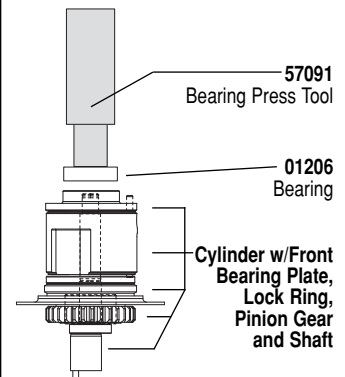

## Special Repair Tools



**96232 (#2) Arbor Press**

- This arbor press is ideal for the disassembly and assembly of air motors.



**96283 Motor Repair Kit:**

- Contains special tools for disassembly/assembly of machine.



**96346 2" Bearing Separator**

- Use the separator to remove gears and bearings.

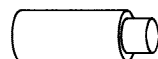

**96213 Bearing Removal Tool**

- This tool is used to pass through the I.D. of the bearing plate and to push against the I.D. of the bearing.



**96343 Retaining Ring Pliers**

- Internal/external retaining ring pliers. Tip diameter - 0.038" (0.96mm)

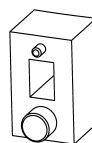

**96182 Removal Tool**

- Has a 3/8" square socket for use with 3/8" drive; breaker bar, ratchet head, or torque wrenches.

# Preventative Maintenance Schedule

For All 11" Gear-Driven Sander

This service chart is published as a guide to expectant life of component parts. The replacement levels are based on average tool usage over one year. Dynabrade Inc. considers one year usage to be 1,000 hours or 50% of a man year. Parts included in motor tune-up kit are identified by High Wear and Medium Wear items.

## Parts Common to all Models:

LEGEND	
T	Included in Tune-Up Kit
X	Type of wear, no other comments apply.
L	Easily lost. Care during assembly/disassembly.
D	Easily damaged during assembly/disassembly.
R	Replace each time tool is disassembled.



98576 – Motor Tune-Up Kit

Index #	Part Number	Description	Number Required	High Wear 100%	Medium Wear 70%	Low Wear 30%	Non-Wear 10%
1	97010	Screw	5			L	
2	95886	Washer	5			L	
3	56231	11" Pad	1			X	
4	96477	Screw	1			L	
5	59277	11" Balance Arm Assy	1				X
6	56474	Balancer Washer	1			L	
7	58452	Mount Plate Assembly Includes: 96423 Bearing	1		T		X
8	See Note	Shroud	1			X	
9	01673	Pin	1			D	
10	56589	Shaft	1				X
11	54673	Key	1		T		
12	56133	Bearing	1		T		
13	57749	Pinion Gear	1			X	
14	57332	Lock Ring	1				X
15	96166	Set Screw	1			L	
16	56559	Front Bearing Plate	1			X	
17	54705	Rotor/Blade Set (5/pkg.)	1	T			
18	56495	Cylinder (95865 & 96313 Pin)	1			X	
19	95911	O-Ring	1		T		
20	54629	Rear Bearing Plate	1			X	
21	01206	Bearing	1		T		
22	95626	Retaining Ring	1		T		
23	See Note	Housing (Includes: 56581 Grip)	1				X
24	95627	Pin	1		T		
25	56582	Safety Throttle Lever	1				X
26	98459	O-Ring	1		T		
27	56579	Valve Stem	1		T		
28	56578	Speed Regulator	1			X	
29	01025	O-Ring	3		X		
30	56598	Seal	1		T		
31	51944	Tip Valve	1		T		
32	51943	Spring	1		T		
33	56586	Vacuum Plug	1			X	
34	56469	Exhaust Gasket	1		T		
35	96459	O-Ring	1		T		
36	56468	Handle (Includes: 51938 Screen)	1			X	
37	96469	Screw	2			X	
38	96454	Screw	2			X	
39	56597	Muffler	1		T		
40	56596	Muffler Clip	1		T		

Note: Please refer to page 4 of tool manual for specific part number.

## Optional Accessories

FIND THE MOST CURRENT OFFERING OF SUPPORT DOCUMENTS AND ACCESSORIES @ WWW.DYNABRADE.COM



### 98576 Motor Tune-Up Kit

- Includes assorted parts to help maintain and repair motor.

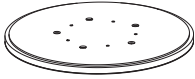

### Optional 11" Pads:

- 56230 Vinyl
- 56232 Loop-Face
- 56220 HookIt™ II Interface Pad
- 56231 Hook-Face
- 53997 Hook-Face, Vac (15 Hole)
- 53998 Interface Pad (Hook-Face)

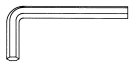

- 95134 – 9/64" Hex Wrench
- 95135 – 5/32" Hex Wrench



### Dynabrade Air Lube

- Formulated for pneumatic equipment.
- Absorbs up to 10% of its weight in water.
- Prevents rust and formation of sludge.
- Keeps pneumatic tools operating longer with greater power and less down time.

95842: 1 pt. (473 ml)

95843: 1 gal. (3.8 L)



### 95542 Grease 10 oz.

- Multi-purpose grease for all types of bearings, cams, gears.
- High film strength; excellent resistance to water, steam, etc.
- Workable range 0° F to 300° F.



### 95541 Push-type Grease Gun

- One-hand operation.

## Reference Contact Information

- American National Safety Institute – ANSI**  
1899 L Street, NW 11th Floor  
Washington, DC 20036  
202-293-8020
- Government Printing Office – GPO**  
Superintendent of Documents  
Attn. New Orders  
P.O. Box 371954  
Pittsburgh, PA 15250-7954  
Tel: 1 (202) 512-1803
- European Committee for Standardization**  
Rue de Stassart 36  
B - 1050 Brussels, Belgium



Visit Our Web Site: [www.dynabrade.com](http://www.dynabrade.com)

Email: [Customer.Service@Dynabrade.com](mailto:Customer.Service@Dynabrade.com)

**DYNABRADE, INC.**, 8989 Sheridan Drive • Clarence, NY 14031-1490 • Phone: (716) 631-0100 • Fax: 716-631-2073 • International Fax: 716-631-2524  
**DYNABRADE EUROPE S.à.r.l.**, Zone Artisanale • L-5485 Wormeldange—Haut, Luxembourg • Telephone: 352 76 84 94 1 • Fax: 352 76 84 95 1

©DYNABRADE, INC., 2013 12/13

PRINTED IN USA