

# RED-TRED® Eraser Disc Pistol Grip Tool, 2,500 RPM

*Air Tool Manual – Safety, Operation and Maintenance*

SAVE THIS DOCUMENT, EDUCATE ALL PERSONNEL

**Models:**

- 18069** – 5/8"-11 Spindle
- 18071** – Eraser/Buffering Versatility Kit (5/8"-11)
- 18072** – M14 x 2 Spindle
- 18073** – Eraser/Buffering Versatility Kit (M14 x 2)

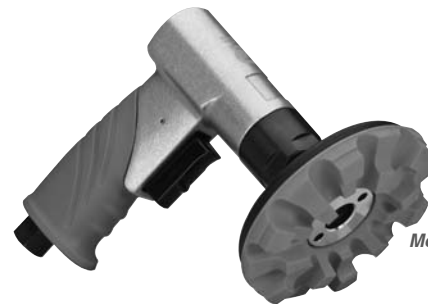

Model 18069  
Shown

FIND THE MOST CURRENT OFFERING OF SUPPORT DOCUMENTS AND ACCESSORIES AT [WWW.DYNABRADEAUTO.COM](http://WWW.DYNABRADEAUTO.COM)

## ⚠ WARNING

Read and understand this tool manual before operating your air tool. Follow all safety rules for the protection of operating personnel as well as adjacent areas. Always operate, inspect and maintain this tool in accordance with the American National Standards Institute (ANSI) Safety Code for Portable Air Tools – B186.1. For additional safety information, refer to Safety Requirements for the Use, Care and Protection of Abrasive Wheels – ANSI B7.1, Code of Federal Regulation – CFR 29 Part 1910, European Committee for Standards (EN) Hand Held Non-Electric Power Tools – Safety Requirements and applicable State and Local Regulations.

## SAFETY LEGEND

	<b>⚠ WARNING</b> Read and understand tool manual before work starts to reduce risk of injury to operator, visitors, and tool.	<b>⚠ WARNING</b> Practice safety requirements. Work alert, have proper attire, and do not operate tools under the influence of alcohol or drugs.	
	<b>⚠ WARNING</b> Eye protection must be worn at all times, eye protection to conform to ANSI Z87.1.	<b>⚠ WARNING</b> Ear protection to be worn when exposure to sound, exceeds the limits of applicable Federal, State or local statutes, ordinances and/or regulations.	
	<b>⚠ WARNING</b> Respiratory protection to be used when exposed to contaminants that exceed the applicable threshold limit values required by law.	<b>⚠ WARNING</b> Air line hazard, pressurized supply lines and flexible hoses can cause serious injury. Do not use damaged, frayed or deteriorated air hoses and fittings.	

### ⚠ WARNING

Some dust created by sanding, grinding, drilling, and other construction activities contain chemicals known to cause cancer, birth defects or other reproductive harm. Some examples of these chemicals are:

- Lead from lead-based paints
- Crystalline silica from bricks and cement and other masonry products
- Arsenic and chromium from chemically treated lumber

Your risk from these exposures varies, depending on how often you do this type of work. To reduce your exposure to these chemicals: work in a well ventilated area, and work with approved safety equipment, such as those dust masks that are specially designed to filter out microscopic particles.

### SAFETY INSTRUCTIONS

Carefully Read all instructions before operating or servicing any Dynabrade® Abrasive Power Tool.

Products offered by Dynabrade are not to be modified, converted or otherwise altered from the original design.

**Tool Intent:** RED-TRED® Eraser Disc Tool uses eraser discs for erasing and removing tapes, adhesives, vinyl graphics, pin striping and decals without harming the substrate.

**Do Not Use Tool For Anything Other Than Its Intended Applications.**

This power tool is not intended for use in potentially explosive atmospheres and is not insulated against contact with electrical power.

**Training:** Proper care, maintenance, and storage of your tool will maximize its performance.

- Employer's Responsibility – Provide RED-TRED® Eraser Disc Tool operators with safety instructions and training for safe use of tools and accessories.

**Accessory Selection:**

- ONLY USE Dynabrade Eraser Discs (P/N 92297).
- Accessory speed rating MUST be approved for AT LEAST the tool Revolutions Per Minute (RPM) rating.

## SAFETY INSTRUCTIONS (Continued)

- DO NOT USE cut-off wheels or grinding wheels on this tool.
- Before mounting an accessory, visually inspect for defects. Do not use defective accessories.
- Only use recommended fittings and air line sizes. Air supply hoses and air hose assemblies must have a minimum working pressure rating of 150 PSIG (10 bars) or 150 percent of the maximum pressure produced in the system, whichever is higher.

## OPERATING INSTRUCTIONS

**Warning:** Always wear eye protection. Operator of tool is responsible for following: accepted eye, face, respiratory, hearing and body protection.

**Caution:** Hand, wrist and arm injury may result from repetitive work, motion and overexposure to vibration.

**Warning:** Be sure that any loose clothing, hair and all jewelry is properly restrained.

- Keep hand and clothing away from moving end of the air tool which has a potential hazard of cutting.
- Install air fitting into inlet bushing of tool. Important: Secure inlet bushing of tool with a wrench before attempting to install the air fitting to avoid damaging valve body housing.

**Warning:** Check free speed of RED-TRED® Eraser Disc Tool regularly using a tachometer without an accessory attached. Test with 90 PSIG at the inlet while tool is running. Always check tool speed after any maintenance or repair. If tool is operating at a higher RPM (speed) than marked on the housing, or operating improperly, the tool must be corrected before use.

**Warning:** Tool must never exceed accessory RPM rating. Check accessory manufacturer for details on maximum operating speed or special mounting instructions.

- Disconnect tool from air supply when changing recommended accessories.
- Completely press all six raised tabs on the eraser disc into the erase hub. Once in place fasten the flange nut using provided 96507 Pin Wrench to secure the hub and eraser to the spindle.
- Connect air tool to power source. Be careful NOT to depress throttle lever in the process.

**Do not expose air tool to inlet pressure above 90 PSIG or (6.2 Bars).**

**Caution:** After installing the accessory, before testing or use and/or after reassembling tool, the tool must be started at a reduced speed to check for good balance. Gradually increase tool speed. DO NOT USE if tool vibration is excessive. Correct cause, and retest to insure safe operation.

**Warning:** Use only appropriately sized eraser properly secured and centered to the hub provided with the RED-TRED® Eraser Disc Tool.

- Make sure that work area is uncluttered, and visitors are at a safe range from the tools and debris.

**Warning:** Potentially explosive atmospheres can be caused by dust and fumes resulting from erasing. Always use dust extraction or suppression systems which are suitable for the material being processed.

- Use only Dynabrade lubricants. See Maintenance Instructions.
- Use a vise or clamping device to hold work piece firmly in place.
- Work may generate hazardous dust.
- Always be aware of bystanders in work areas.
- DO NOT apply excessive force on tool or apply "rough" treatment to it.
- Always work with a firm footing, posture and proper lighting.
- Release the throttle lever in case of an interruption of the energy supply.
- Ensure that sparks and debris resulting from work do not create a hazard such as a fire or explosion.
- Tool is rear exhaust. Exhaust air may contain lubricants, grease, and other materials flushed through the tool.

**Report to your supervisor any condition of the tool, accessories, or operation you consider unsafe.**

## Air System

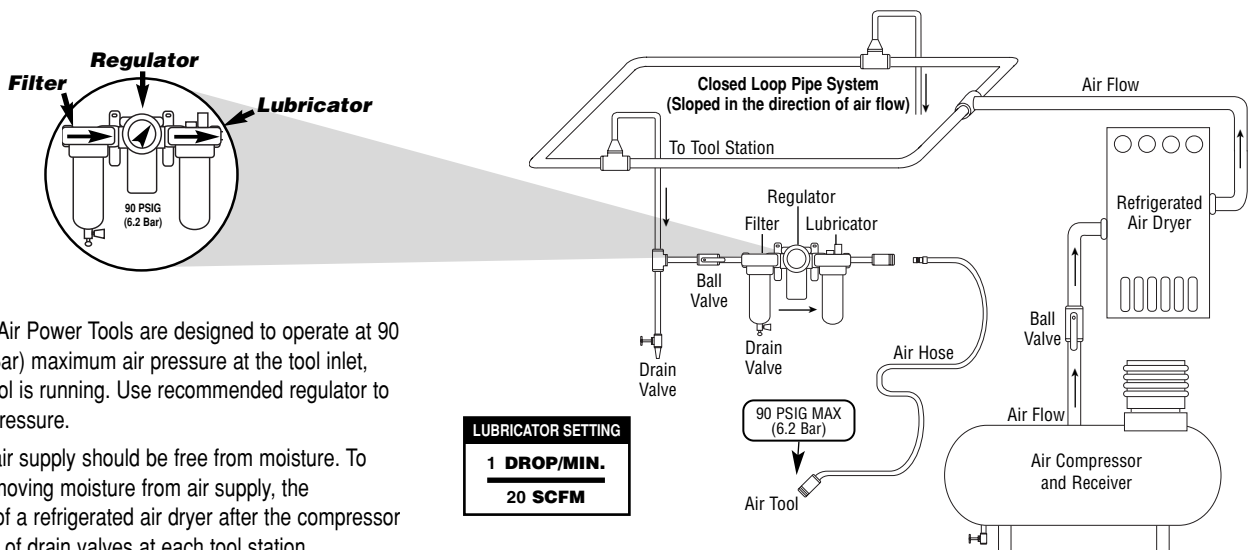

- Dynabrade Air Power Tools are designed to operate at 90 PSIG (6.2 Bar) maximum air pressure at the tool inlet, when the tool is running. Use recommended regulator to control air pressure.
- Ideally the air supply should be free from moisture. To facilitate removing moisture from air supply, the installation of a refrigerated air dryer after the compressor and the use of drain valves at each tool station is recommended.

**LUBRICATOR SETTING**  
**1 DROP/MIN.**  
**20 SCFM**

# RED-TRED® Eraser Disc Tool

## Complete Assembly

**KEY**

- O** Oil: O<sub>1</sub> = Air Lube
- A** Adhesive: A<sub>2</sub> = Loctite #271
- T** Torque: N·m x 8.85 = In. - lbs.
- G** Grease: G<sub>1</sub> = Lubriplate 630AA

Always follow adhesive manufacturers cleaning and priming recommendations.

**Index Key**

No.	Part #	Description
1	18366	Spindle Nut
2	18367	Gear Housing
3	18368	Bearing
4	18370	Gear (3)
5	18369	Planetary Carrier
6	18371	Pin (3)
7	18372	Ring Gear
8	18373	Bearing
9	18374	Spacer
10	18375	Bearing
11	18376	Front End Plate
12	18377	Rotor Spacer
13	18378	Rotor
14	18379	Vane (5)
15	18380	Cylinder
16	18381	Pin
17	18382	Rear End Plate
18	18383	Bearing
19	18384	Speed Regulator
20	18385	O-Ring
21	18386	Housing
22	18387	Pin
23	18388	Trigger
24	18389	Muffler
25	18390	Exhaust Deflector
26	18391	O-Ring
27	18392	Valve Bushing
28	18393	Valve Seat
29	18394	Tip Valve
30	18395	Valve Spring
31	18396	Inlet Bushing
32	18397	Grip
33	92298	Eraser Hub
34	92297	Eraser Disc
35	<b>Flange Nut</b>	
	04127	5/8"-11
	04128	M14 x 2
36	50126	3" Pad (Hook-Face)

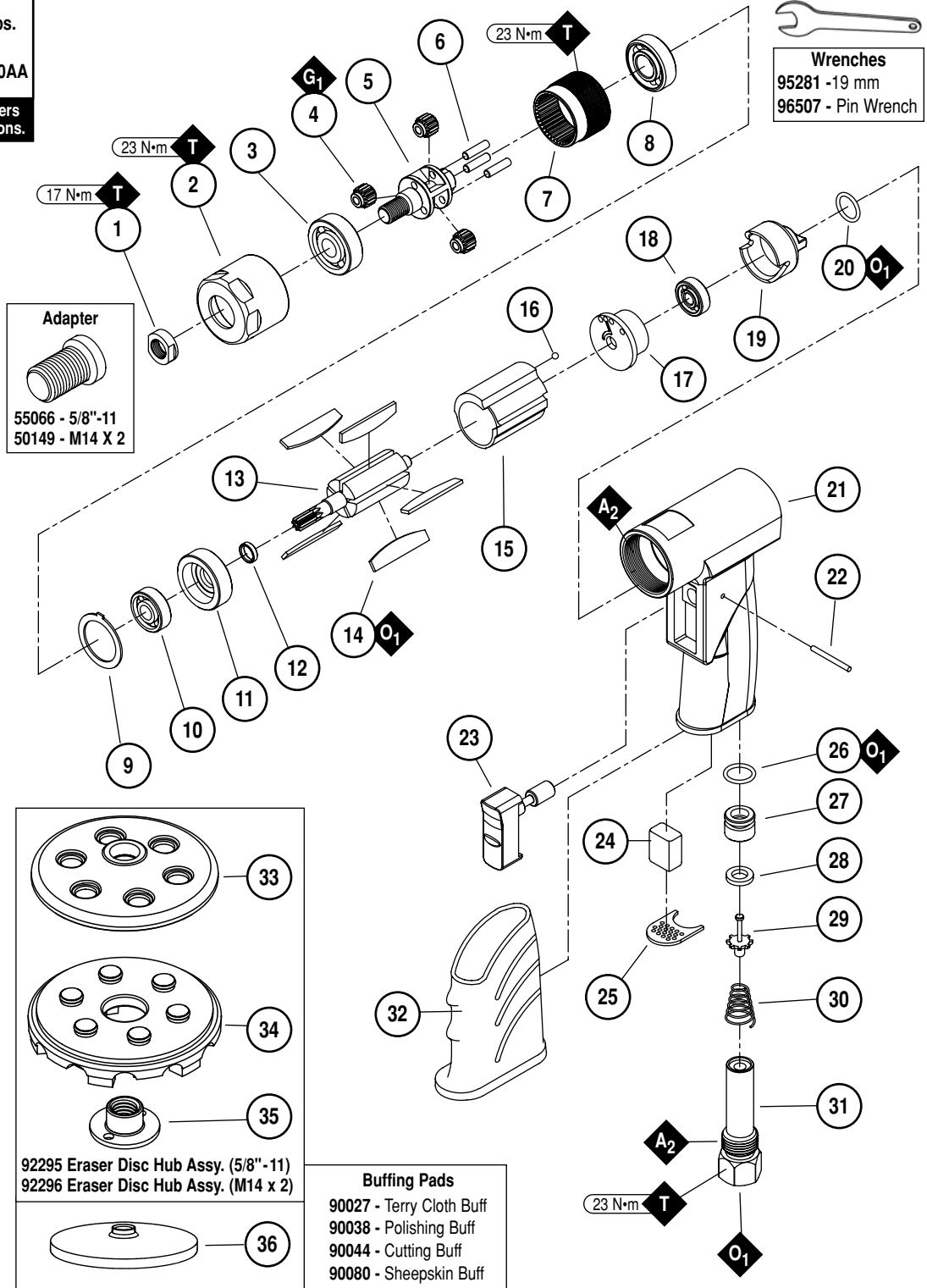

**Wrenches**  
 95281 - 19 mm  
 96507 - Pin Wrench

## Machine Specifications

Model Number	Motor RPM	Diameter Inch (mm)	Sound Level	Max. Air Flow SCFM (LPM)	Weight Pound (kg)	Length Inch (mm)	Height Inch (mm)	Spindle Thread
18069/18072	2,500	4 (96) Eraser Disc	80 dB(A)	23 (651)	2.5 (1.1)	5.3 (135)	7 (179)	5/8"-11 or M14 x 2
18071/18073	2,500	3 (72) Backing Pad	80 dB(A)	23 (651)	1.7 (.8)	5 (128)	6-3/8 (179)	3/8"-24

Additional Specifications: Air Inlet Thread 1/4" NPT • Hose I.D. 1/4" (6 mm) • Inlet Pressure: 90 PSIG (6.2 Bar)  
 Sound Level is the pressure measurement according to the method outlined in ISO regulation ISO-15744

# Maintenance Instructions

**Important:** To keep tool safe a Preventative Maintenance Program is recommended whenever portable power tools are used.

- Use only genuine Dynabrade replacement parts to insure quality. To order replacement parts, specify **Model#**, **Serial#** and **RPM** of your air tool.
- It is strongly recommended that all Dynabrade air tools be used with a Filter-Regulator-Lubricator to minimize the possibility of misuse due to unclean air, wet air or insufficient lubrication. Dynabrade recommends the following: **10681** Air Filter-Regulator-Lubricator (FRL) – Provides accurate air pressure regulation and two stage filtration of water contaminates.
- Dynabrade recommends one drop of air lube per minute for each 20 SCFM (example: if the tool specification states 40 SCFM, set the drip rate on the filter-lubricator to 2 drops per minute). Dynabrade Air Lube (P/N **95842**: 1 pt 473 ml) is recommended.

**Routine Preventative Maintenance:** Check free speed of RED-TRED® Eraser Disc Tool regularly using a tachometer without an accessory attached. Test with 90 PSIG at the inlet while tool is running. Always check tool speed after any maintenance or repair. If tool is operating at a higher RPM (speed) than marked on the housing, or operating improperly, the tool must be corrected before use.

- Mineral spirits are recommended when cleaning the tool and parts. Do not clean tool or parts with any solvents or oils containing acids, esters, ketones, chlorinated hydrocarbons or nitro carbons.
- **DO NOT** clean or maintain tools with chemicals that have a low flash point (example: WD-40®).
- Air tool stampings must be kept legible at all times, if not, reorder and replace. User is responsible for maintaining specification information. i.e.: Model #, S/N, and RPM.
- Blow air supply hose out prior to initial use.
- Visually inspect air hoses and fittings for frays, visible damage and signs of deterioration. Replace damaged or worn components.
- Refer to Dynabrade's Pneumatic Tool Safety Guidelines (Reorder No. **00001676**) for general and specific safety information.

After maintenance is performed on tool, add a few drops of Dynabrade Air Lube (P/N **95842**) to the air line and start the tool a few times to lubricate air motor. Check for excessive tool vibration.

## Handling and Storage:

- Use of tool rests, hangers and/or balancers is recommended.
- Protect tool inlet from debris.
- **DO NOT** carry tool by air hose or throttle lever.
- Protect accessories from exposure to water, high humidity, freezing temperature and extreme temperature changes.
- Store accessories in protective racks or compartments to prevent damage.

## Autobrade Red Tool Warranty

Following the reasonable assumption that any inherent defect which might prevail in a product will become apparent to the user within **1 year** from the of date purchase, "Autobrade Red" tools are warranted against defects in workmanship and materials under normal use and service.

**We shall, at our option, repair or replace at our factory, any "Autobrade Red" tool which shall, within 1 year after delivery to the original purchaser, indicate upon our examination to have been defective.**

Our obligation is contingent upon proper use of "Autobrade Red" tools in accordance with factory recommendations, instructions and practices.

### The warranty shall not apply in these cases:

1. Normally wearable parts such as bearings, rotor blades, etc.
2. Consumables such as erasing pads, etc.
3. Misuse, neglect in maintaining tool or tool modification.
4. Lack of lubrication or evidence of rust, dirt or corrosion.
5. Tools requiring normal tune-up or cleaning.
6. Tools being used after they are badly worn such as using ratchet with worn yoke.
7. Ratchets, anvils damaged by excessive hand torquing.
8. Use in production-type applications.



Products to be considered for warranty must be sent back to our factory, transportation prepaid by the user. Please send tool back to attention of "Repair Department" with note fully explaining the nature of the problem along with a copy of original invoice indicating model and serial number.

**Return product to:**  
**Dynabrade, Inc.**  
**Attn: Repair Department**  
**8989 Sheridan Dr.**  
**Clarence, NY 14031**

## Reference Contact Information

1. **American National Standards Institute – ANSI**  
25 West 43<sup>rd</sup> Street  
Forth Floor  
New York, NY 10036  
Tel: 1 (212) 642-4900  
Fax: 1 (212) 398-0023
2. **Government Printing Office – GPO**  
Superintendent of Documents  
Attn. New Orders  
P.O. Box 371954  
Pittsburgh, PA 15250-7954  
Tel: 1 (202) 512-1803
3. **Power Tool Institute, Inc.**  
P.O. Box 818  
Yachata, Oregon 97498-0818  
Tel: 1 (503) 547-3185  
Fax: 1 (503) 547-3539
4. **European Committee for Standardization**  
Rue de Stassart 36  
B - 1050 Brussels, Belgium



Visit Our Web Site: [www.dynabradeauto.com](http://www.dynabradeauto.com)