

5" & 6" Two Hand Dynorbital® Sander

Air Powered, Random 3/8" Orbital Sander, 12,000 RPM

Models:

- 59200 – 5" Non-Vacuum
- 59201 – 5" Vac-Ready
- 59204 – 5" Central Vac-Ready
- 59210 – 6" Non-Vacuum
- 59211 – 6" Vac-Ready
- 59214 – 6" Central Vac-Ready

WARNING

Always operate, inspect and maintain this tool in accordance with the Safety Code for portable air tools (ANSI B186.1) and any other applicable safety codes and regulations. Please refer to Dynabrade's Warning/Safety Operating Instructions for more complete safety information.

Index Key

No.	Part #	Description
1	56104	5" Vac Sanding Pad
	56105	6" Vac Sanding Pad
	56106	5" Non-Vac Sanding Pad
	56107	6" Non-Vac Sanding Pad
2	95858	Spacer
2A	95859	Spacer
3	95886	Washer (4) (CVR)
4	96425	Screw (4) (CVR)
5	57737	6" Vacuum Shroud
6	57369	Lip Seal Shroud
7	96166	Set Screw
8	57332	Lock Ring
9	57069	Balancer Shaft
10	95630	Snap Ring
11	95628	Bearing Shield
12	56053	Bearing Seal
13	56052	Balancer Bearing
14	56687	5" Motor Shaft Balancer
	56688	6" Motor Shaft Balancer
15	54673	Rotor Key
16	02695	Bearing
17	54630	Front Bearing Plate
18	54705	Rotor/Blade Set
19	54631	Cylinder Assy. (incl. #20)
20	95865	Line-Up Pin
21	54629	Rear Bearing Plate
22	01206	Bearing
23	95626	Retaining Ring
24	57382	Gasket (5", 6" Non-Vac 6" Central Vac)
	57383	Gasket (5", 6" Vac-Ready 5" Central Vac)
25	59246	Housing - 59200
	59247	Housing - 59201
	59248	Housing - 59204
	59249	Housing - 59210
	59254	Housing - 59211
	59255	Housing - 59214
26	95523	O-Ring (2)
27	56671	Handle
28	96123	Screw (2)
29	57396	Valve Stem
30	95886	Flat Washer (4)
31	01211	Split Lock Washer (6)
32	97010	Screw (4)
33	01464	Seal (2)
34	01472	Tip Valve
35	01468	Conical Spring
36	56673	Gasket
37	96328	O-Ring
38	98597	Retaining Ring
39	56672	Adapter Assembly
40	01024	O-Ring (2)
41	57343	Speed Regulator
42	54199	Muffler Seat
43	54195	Muffler (3)
44	54194	Muffler Cap
45	57344	Throttle Lever
46	01017	Pin
47	96421	Flat Washer (2)
48	01788	Screw (2)
49	01494	Inlet Bushing

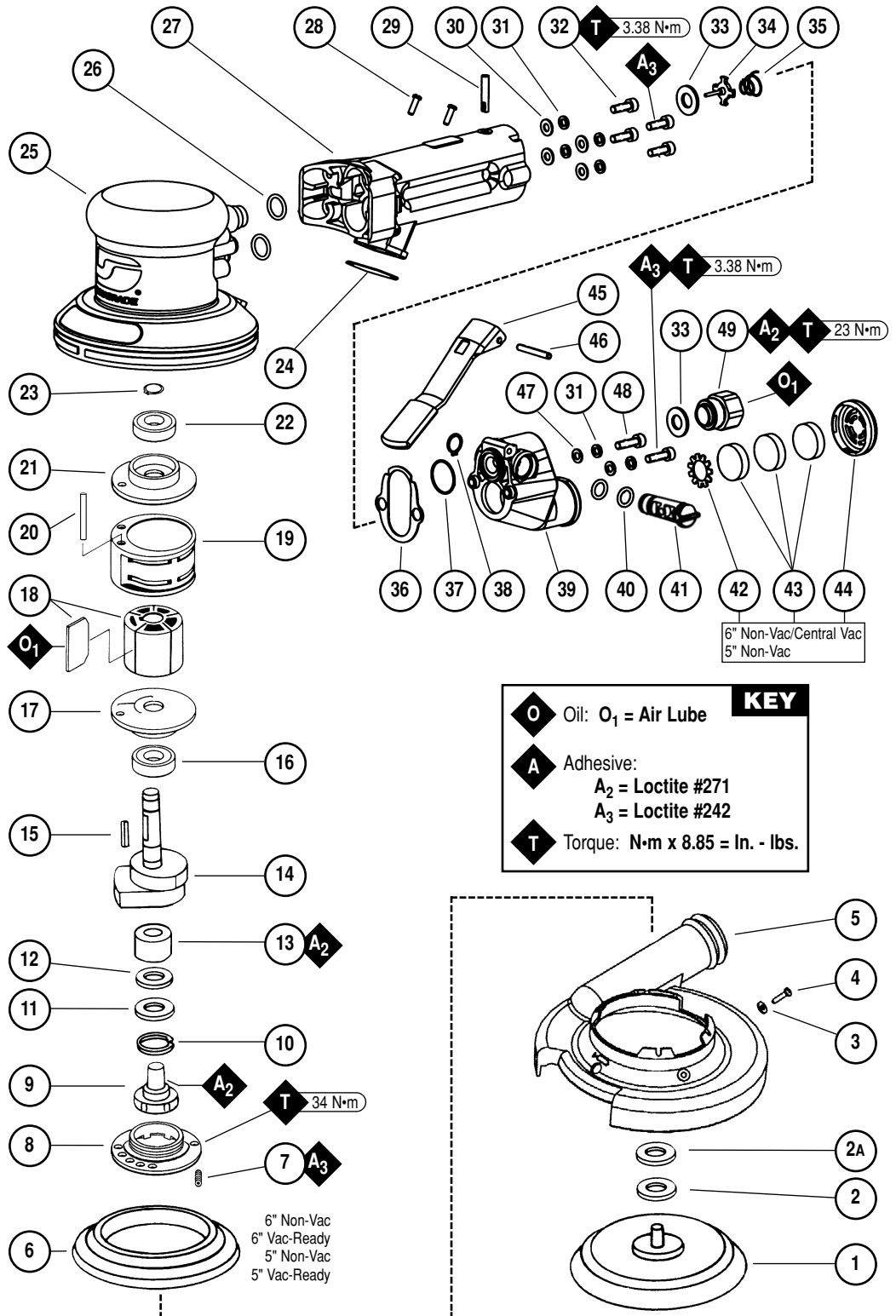

KEY

- O** Oil: O₁ = Air Lube
- A** Adhesive:
 - A₂ = Loctite #271
 - A₃ = Loctite #242
- T** Torque: N·m x 8.85 = in. - lbs.

Important Operating, Maintenance and Safety Instructions

Carefully read all instructions before operating or servicing any Dynabrade® Abrasive Power Tool.

Warning: Hand, wrist and arm injury may result from repetitive work motion and overexposure to vibration.

Important: All Dynabrade Rotary Vane air tools must be used with a Filter-Regulator-Lubricator to maintain all warranties.

Operating Instructions:

Warning: Eye, face, respiratory, sound and body protection must be worn while operating power tools. Failure to do so may result in serious injury or death. Follow safety procedures posted in workplace.

1. With power source disconnected from tool, securely fasten abrasive/accessory on tool.
2. Install air fitting into inlet bushing of tool.

Important: Secure inlet bushing of tool with a wrench before attempting to install the air fitting to avoid damaging valve body housing.

3. Connect power source to tool. Be careful not to depress throttle lever in the process.

Maintenance Instructions:

1. Check tool speed regularly with a tachometer. If tool is operating at a higher speed than the RPM marked on the tool, the tool should be serviced to correct the cause before use.
2. Some silencers on air tools may clog with use. Clean and replace as required.
3. All Dynabrade Rotary Vane air motors should be lubricated. Dynabrade recommends one drop of air lube per minute for each 10 SCFM (example: if the tool specifications state 40 SCFM, set the drip rate of your filter-lubricator at 4 drops per minute). Dynabrade Air Lube (P/N **95842**: 1pt. 473ml.) is recommended.
4. An Air Line Filter-Regulator-Lubricator must be used with this air tool to maintain all warranties. Dynabrade recommends the following: **11405** Air Line Filter-Regulator-Lubricator — Provides accurate air pressure regulation, two-stage filtration of water contaminants and micro-mist lubrication of pneumatic components. Operates 40 SCFM @ 100 PSIG has 3/8" NPT female ports.
5. Use only genuine Dynabrade replacement parts. To reorder replacement parts, specify the **Model #**, **Serial #**, and **RPM** of your machine.
6. A Motor Tune-Up Kit (P/N **96122**) is available which includes assorted parts to help maintain motor in peak operating condition. Please refer to Dynabrade's Preventative Maintenance Schedule for a guide to expectant life of component parts.
7. Mineral spirits are recommended when cleaning the tool and parts. Do not clean tool or parts with any solvents or oils containing acids, esters, keytones, chlorinated hydrocarbons or nitro carbons.

Safety Instructions:

Products offered by Dynabrade should not be converted or otherwise altered from original design without expressed written consent from Dynabrade, Inc.



- **Important:** User of tool is responsible for following accepted safety codes such as those published by the American National Standards Institute (ANSI).
- Always disconnect power supply before changing abrasive/accessory or making machine adjustments.
- Inspect abrasives/accessories for damage or defects prior to installation on tools.
- Please refer to Dynabrade's Warning/Safety Operating Instructions Tag (Reorder No. **95903**) for more complete safety information.

Notice

All Dynabrade motors use the highest quality parts and metals available and are machined to exacting tolerances. The failure of quality pneumatic motors can most often be traced to an unclean air supply or the lack of lubrication. Air pressure easily forces dirt or water contained in the air supply into motor bearings causing early failure. It often scores the cylinder walls and the rotor blades resulting in limited efficiency and power. Our warranty obligation is contingent upon proper use of our tools and cannot apply to equipment which has been subjected to misuse such as unclean air, wet air or a lack of lubrication during the use of this tool.

Full One Year Warranty

Following the reasonable assumption that any inherent defect which might prevail in a product will become apparent to the user within one year from the date of purchase, all equipment of our manufacture is warranted against defects in workmanship and materials under normal use and service. We shall repair or replace at our factory, any equipment or part thereof which shall, within one year after delivery to the original purchaser, indicate upon our examination to have been defective. Our obligation is contingent upon proper use of Dynabrade tools in accordance with factory recommendations, instructions and safety practices. It shall not apply to equipment which has been subject to misuse, negligence, accident or tampering in any way so as to affect its normal performance. Normally wearable parts such as bearings, contact wheels, rotor blades, etc., are not covered under this warranty.

Model Number	Motor HP (W)	Motor RPM	Pad Dia. Inch (mm)	Sound Level	Air Flow Rate CFM/SCFM (LPM)	Air Pressure PSIG (Bars)	Weight Pound (kg)	Length Inch (mm)	Height Inch (mm)
59200	.4 (298)	12,000	5 (127)	78 dB(A)	4/27 (765)	90 (6.2)	2.7 (1.2)	10-1/4 (260)	4-1/2 (114)
59201	.4 (298)	12,000	5 (127)	82 dB(A)	4/27 (765)	90 (6.2)	2.7 (1.2)	10-1/4 (260)	4-1/2 (114)
59204	.4 (298)	12,000	5 (127)	86 dB(A)	4/27 (765)	90 (6.2)	2.7 (1.2)	10-1/4 (260)	4-1/2 (114)
59210	.4 (298)	12,000	6 (152)	82 dB(A)	4/27 (765)	90 (6.2)	4.5 (2.0)	10-1/2 (267)	4-1/2 (114)
59211	.4 (298)	12,000	6 (152)	88 dB(A)	4/27 (765)	90 (6.2)	4.5 (2.0)	10-1/2 (267)	4-1/2 (114)
59214	.4 (298)	12,000	6 (152)	84 dB(A)	4/27 (765)	90 (6.2)	4.5 (2.0)	10-1/2 (267)	4-1/2 (114)

Additional Specifications: Orbit Diameter 3/8" (10 mm) • Spindle Thread 5/16"-24 Female • Air Inlet Thread 1/4" NPT • Hose Size 3/8" (8 mm)

Motor Assembly/Disassembly Instructions

Important: Manufacturer's warranty is void if tool is disassembled before warranty expires.

These instructions are for use in conjunction with Part Number 57260 Repair Kit, which includes special tools for proper disassembly/assembly of tool. A complete Tune-Up Kit, Part Number 96122 is available which includes assorted parts to help maintain and repair motor.

To Disassemble:

1. Invert machine and secure in vise, using 57092 Collar (supplied in 57260 Repair Kit) or padded jaws.
2. Remove sanding pad with 50679 Open-End Wrench (supplied with sander).
3. Using a 2 mm hex key remove the 96166 Set Screw.
4. Insert 56058 Lock Ring Wrench (supplied in 57260 Repair Kit) into corresponding tabs of lock ring and unscrew. Motor may now be lifted out for service. **Important: Do not remove the rubber seals from the motor housing.**
5. Remove 95626 Retainer Ring. Motor may now be disassembled.
6. Remove the rear plate assembly by securing the 54631 Cylinder in a standard 2 inch bearing separator or use a standard bearing puller gripped on the cylinder inlet/exhaust area. Push the motor shaft balancer through the bearing. Remove cylinder, rotor, vanes and key.
7. Remove 54630 Front Plate and press off 02695 Front Motor Bearing, using a 2 inch bearing separator and a #2 arbor press.
8. Remove 01206 Bearing from the 54629 Rear Bearing Plate.
9. Disassemble the balancer assembly as follows:
 - a.) Remove 95630 Snap Ring. Screw the threaded portion of the 56056 Bearing Puller (supplied in 57260 Repair Kit) into the 57069 Balancer Shaft. **Note:** Heat the outside of the motor shaft balancer to approximately 200° F. Now, using the slider weight, pull the assembly out.
 - b.) Press off 56052 Bearing and remove loose parts.
10. If during step 8, the 56052 Bearing remains in the motor shaft balancer, it can be removed by heating the shaft balancer again and using the 56081 Bearing Chuck, 56080 Bearing Puller Stud, 95334 Hex Nut connected to the 56056 Balancer Bearing Puller Assembly. Remove the bearing.

To Assemble:

Important: Be certain parts are clean and in good repair before assembling.

1. Assemble the balancer assembly as follows:
 - a.) Install 95630 Snap Ring onto 57069 Balancer Shaft. Install 95628 Shield with convex face toward hex of balancer shaft.
 - b.) Install 56053 Bearing Seal. **Note:** Be certain seal is pressed completely over shaft step.
 - c.) Apply a slight amount of #271 Loctite® (or equivalent) to inside diameter of the 56052 Bearing and the outside diameter of the 57069 Balancer Shaft.
 - d.) Press 56052 Bearing, with seal side toward hex of balancer shaft, up to shaft step using 57091 Bearing Press Tool (supplied in 57260 Repair Kit) (Drawing 1).
2. Place the motor shaft balancer in a soft jaw vise with large end up.
3. Apply a slight amount of #271 Loctite® (or equivalent) on the outside diameter of the 56052 Bearing and slide the balancer shaft assembly into the motor shaft balancer until 56052 Bearing is firmly seated at bottom. Squeeze 95630 Snap Ring into groove in motor shaft balancer to complete the assembly. Remove from vise.
4. Press 02695 Bearing onto the motor shaft balancer down to the shoulder using 57091 Bearing Press Tool (Drawing 2).
5. Install 54630 Front Bearing Plate onto 02695 Bearing and check for smooth rotation (Drawing 3).
6. Place 54673 Rotor Key, 54671 Rotor, and 54674 Blades onto shaft. **Note:** Be certain rotor "floats" easily on the shaft. Because the design of this motor uses a "floating rotor", there is no need to set or adjust gap between the rotor and the end plates.
7. Place 54631 Cylinder over rotor. The "short" line-up pin goes toward the 54630 Front Bearing Plate.
8. Install 01206 Bearing into 54629 Rear Bearing Plate. Place bearing and bearing plate over shaft and "long" end of line-up pin and press fit in place (Drawing 4).
9. Install 95626 Retaining Ring concave side toward motor. **Note:** Be certain that retaining ring is completely pressed down onto its groove on the shaft.
10. Grease the rubber seals inside the housing using a small amount of multi purpose grease or petroleum jelly. **Note:** Be certain that rubber seals in housing have not pulled out of their seat during disassembly. If this has happened re-seat seals by pushing them until they are flush with inside diameter.

Drawing 1

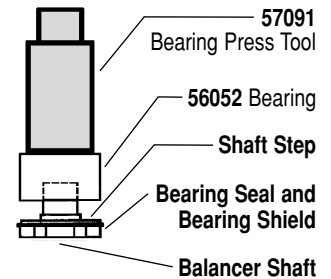

(continued on next page)

Drawing 2

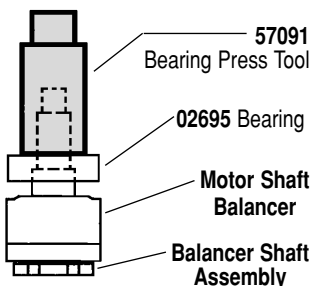

Drawing 3

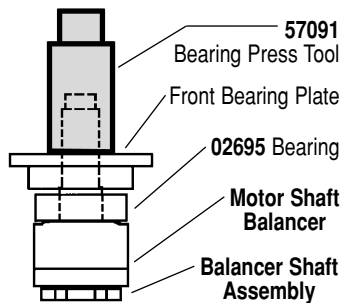

Drawing 4

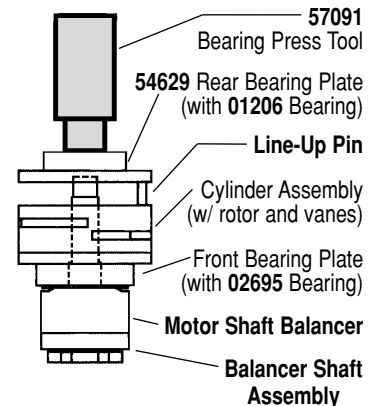

Motor Disassembly/Assembly Instructions (continued)

- Secure motor housing in vise, using **57092** Collar or padded jaws. Slide motor assembly into secured housing.
Note: With handle pointing toward you while looking into motor bore, be certain line-up pin enters slot to right side of center.
- Tighten **57332** Lock Ring with **56058** Lock Ring Tool to 34 N•m/300 on. - lbs. Attach shroud and weight-mated sanding pad.
- Apply one drop of #242 Loctite® (or equivalent) to threads of **96166** Set Screw and reinstall into **57332** Lock Ring. Do not over tighten.

To Disassemble Valve And Speed Regulator Assemblies:

- Invert tool and place in soft jaw vise or use **57092** Repair Collar.
- Loosen and remove **01788** Screws (2), **01211** Lock Washers (2) and **96421** Flat Washers from **56672** Adapter.
- Carefully remove **56672** Adapter making sure no parts fall to the ground. On non-vacuum and central vacuum models: pry off **54194** Muffler Cap and remove **54195** Muffler (3).
- Remove **57343** Speed Regulator by detaching **98597** Retaining Ring with a pair of snap ring pliers. Remove **01024** O-Rings with a small screwdriver.
- Remove tip valve assembly from housing.

To Assemble Valve And Speed Regulator Assemblies:

- Lightly lubricate **01024** O-Rings and slide them on **57343** Speed Regulator. Install through regulator hole on **56672** Adapter. Place **98597** Retaining Ring on groove of speed regulator using a pair of retaining ring pliers.
- Line up hole in valve stem with inlet hole in handle. Place **01464** Seal in handle. Insert **01472** Tip Valve so that metal pin goes through the valve stem. Place **01468** Spring into the housing, small end first. Install **56673** Gasket and **96328** O-Ring.
- Gently line up **56672** Adapter onto handle so no parts shift when tightening. Replace and tighten **01788** Screws (2), **01211** Lock Washers (2), and **96421** Flat Washers (2).

Motor Assembly Complete. Please allow 30 minutes for adhesives to cure before operating tool.

Important: Motor should operate at 12,000 RPM at 6.2 bar (90 PSIG). RPM should be checked with a tachometer. Before operating, we recommend that 3-4 drops of pneumatic tool oil be placed directly into the air inlet with throttle lever depressed. Operate tool for 30 seconds to determine if machine is operating properly and to allow lubricating oils to properly dispense through machine.

Loctite® is a registered trademark of the Loctite Corp.

Accessories

Self-Contained Dust Collection Systems



54290 "Bag-in-Box" System

- **95361** Air Line 5' long.
- **50682** Flex-Hose 1" dia. x 6' long.
- **95362** Rubber Connectors (5).
- **95575** Durable Box Receptacle.
- Sample paper bag included.
Paper bag reorder:
50692 (400/case) or
50693 (24 per package.)



50617, 56303 – 6' Long Flex-Hose Systems

- **50617:** Has **50683** Standard Reusable Felt Bag with hook 'n loop end for easy emptying.
- **56303:** Has **56304** Zipper-Lock Bag. Both systems include 6' long **50682** Flex-Hose. Shown with optional **95361** Air Line (1/4").

Service Kits

96122 Motor Tune-Up Kit:

- Includes assorted parts to help maintain and repair motor.



01089 Safety Lock Lever

- Helps prevent accidental start-up of tool.



57260 Motor Repair Kit:

- Contains special tools for disassembly/assembly of machine.



Visit Our Web Sit: www.dynabrade.com

Email: Customer.Service@Dynabrade.com



DYNABRADE, INC., 8989 Sheridan Drive • Clarence, NY 14031-1490 • Phone: (716) 631-0100 • Fax: 716-631-2073 • International Fax: 716-631-2524
DYNABRADE EUROPE S.à.r.l., Zone Artisanale • L-5485 Wormeldange—Haut, Luxembourg • Telephone: 352 76 84 94 1 • Fax: 352 76 84 95 1

©DYNABRADE, INC., 2001

PRINTED IN USA